



US00D526343S

(12) **United States Design Patent** (10) **Patent No.:** **US D526,343 S**
Laukat et al. (45) **Date of Patent:** **** Aug. 8, 2006**

- (54) **SAXOPHONE NECK**
- (75) Inventors: **Sheryl Laukat**, Sandy, UT (US); **Tevis Laukat**, Sandy, UT (US)
- (73) Assignee: **Cannonball Musical Instruments**, Sandy, UT (US)
- (**) Term: **14 Years**
- (21) Appl. No.: **29/219,447**
- (22) Filed: **Dec. 16, 2004**
- (51) **LOC (8) Cl.** **17-02**
- (52) **U.S. Cl.** **D17/13**
- (58) **Field of Classification Search** D17/10,
D17/13; 84/380 R, 385 R
See application file for complete search history.

(56) **References Cited**

U.S. PATENT DOCUMENTS

1,440,124	A	*	12/1922	Anstett	84/385	R
1,585,295	A	*	5/1926	Loomis	84/385	R
1,632,008	A		6/1927	Lemm			
1,716,929	A		6/1929	Packan			
1,828,389	A		10/1931	Calvani			
1,873,184	A		8/1932	Calvani			
2,020,261	A	*	11/1935	Loney	84/385	R
2,033,774	A		3/1936	Loomis			
2,055,382	A		9/1936	Loomis			
2,151,337	A		3/1939	Selmer			
D145,892	S	*	11/1946	Gillespie	D17/13	
2,425,796	A	*	8/1947	Gillespie	84/385	R
2,555,980	A		6/1951	Loney			
2,846,917	A		8/1958	Lefevre-Selmer			

(Continued)

OTHER PUBLICATIONS

“Yanagisawa Saxophone Necks (Bocals) from Eltham Woodwind and Brass.” *Eltham Woodwind and Brass*. <<http://www.elthamwoodwind.com.au/yanagisawa/bocal.html>>.

“Saxophone Necks by Peter Ponzol.” *Peter Ponzol: Hand-crafted Saxophone Products*. <http://www.peterponzol.com/neck_infro/neck_infomation.htm>.

“PM Woodwind Repair: Saxophone Repair, Used Saxophones, Selmer, Mark VI, Paul Masli . . .” *PM Woodwind*. <<http://www.pmwoodwind.com/instruments.cfm?categoryid=61>>.

“Selmer (Paris) Serie III Polished Brass, Matte lacquered Alto saxophone: Neck from Top.” *SaxForte*. <http://www.saxforte.com/saxophones/Eb_Alto/Eb_Alto_Selmer_Paris_/Serie_III_Alto/Serie_III_Clear_Alto/s3a9.JPG>.

“The Gloger Crook.” *Stephen Howard Woodwind Instrument Repairs & Restoration*. <<http://www.shwoodwind.co.uk/Buying/Gloger.htm>>.

“Unison Saxophone Necks.” *Hollywoodwinds* <<http://www.unionsaxophone.com/necks.html>>.

“Home/Musikinstrumente/Orchesterinstrumente/Holzblasinstrumente/Saxophone/G1.” *Yamaha Deutschland*. <http://www.yamaha-europe.com/yamaha_europe/germany/10_musical_instruments/20_orchestra/10_woodwind/60_saxophones/50_saxophones_necks/G1/index.html/G>.

Primary Examiner—Adir Aronovich
(74) *Attorney, Agent, or Firm*—Starkweather & Associates; Michael W. Starkweather; Jason P. Webb

(57) **CLAIM**

The ornamental design for a saxophone neck, as shown and described.

DESCRIPTION

FIG. 1 is a perspective view of a saxophone neck; FIG. 2 is a right side view of the saxophone neck; FIG. 3 is a left side view of the saxophone neck; FIG. 4 is a front view of the saxophone neck; FIG. 5 is a rear view of the saxophone neck; FIG. 6 is a top plan view of the saxophone neck; and, FIG. 7 is a bottom plan view of the saxophone neck. The portions of the saxophone in broken lines are shown for illustrative purposes only and form no part of the claimed design.

1 Claim, 3 Drawing Sheets

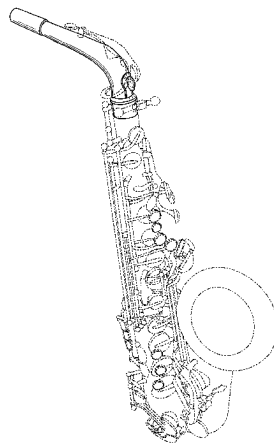

U.S. PATENT DOCUMENTS

3,657,464 A	4/1972	Pascucci	5,900,562 A	5/1999	Smeding	
3,865,005 A	2/1975	Carree	5,990,398 A	11/1999	Nonaka	
4,148,242 A	4/1979	Woehr et al.	6,265,649 B1	7/2001	Smeding	
4,250,791 A	2/1981	Tairadate	6,977,331 B1 *	12/2005	Lin	84/385 R
4,453,445 A	6/1984	Todd				

* cited by examiner

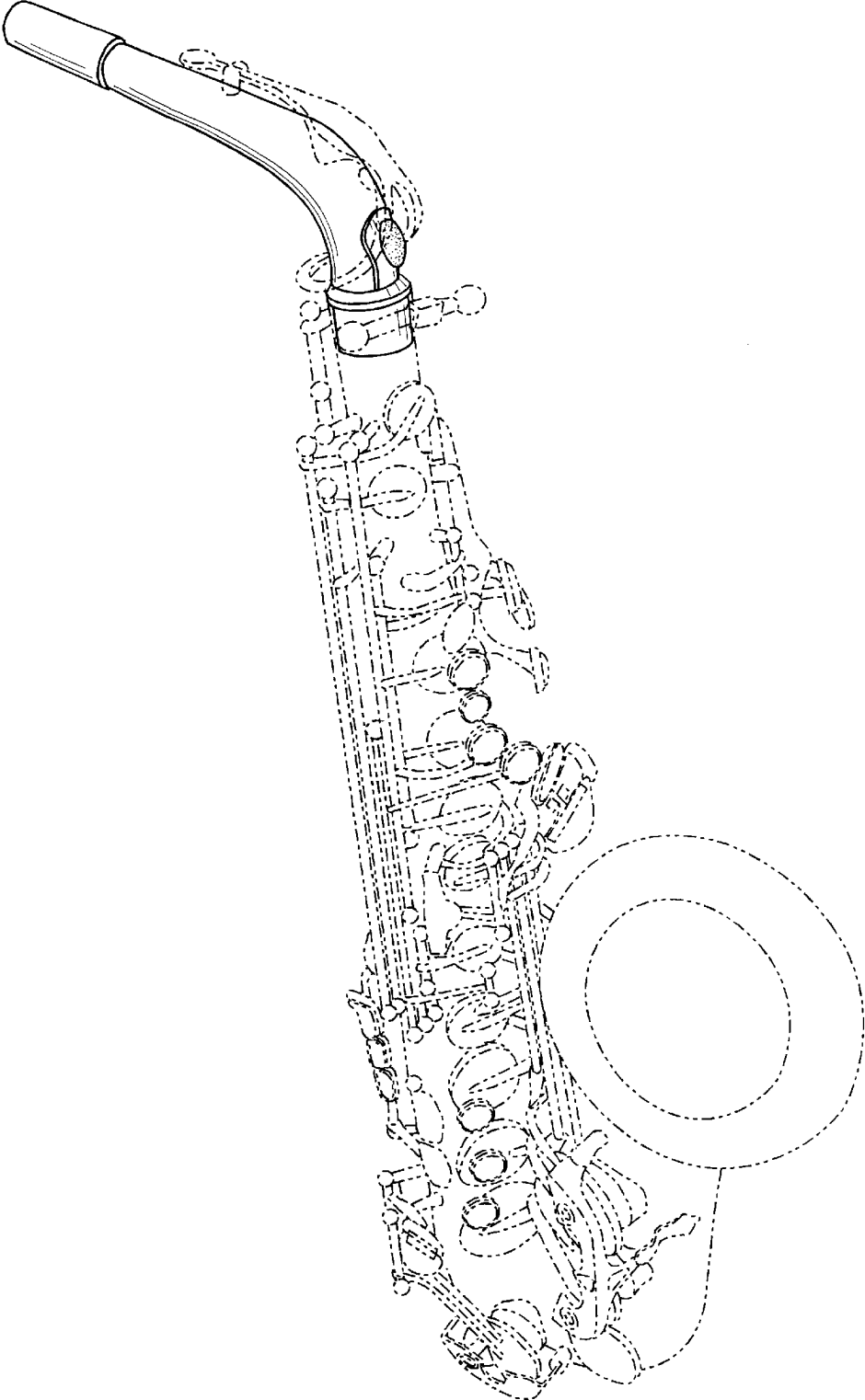

FIG. 1

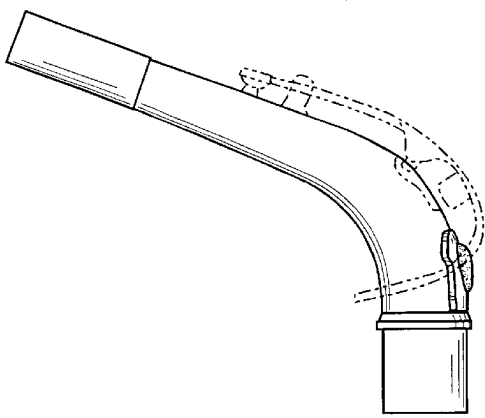

FIG. 2

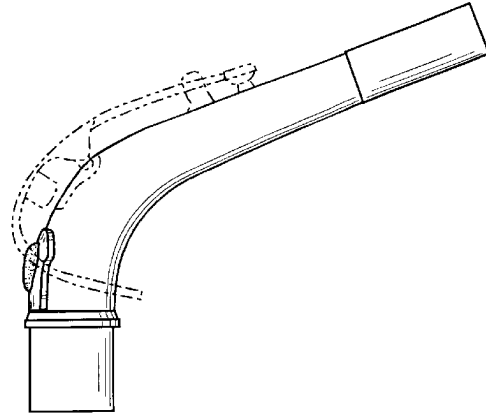

FIG. 3

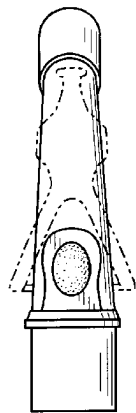

FIG. 4

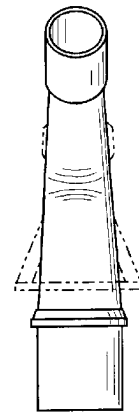

FIG. 5

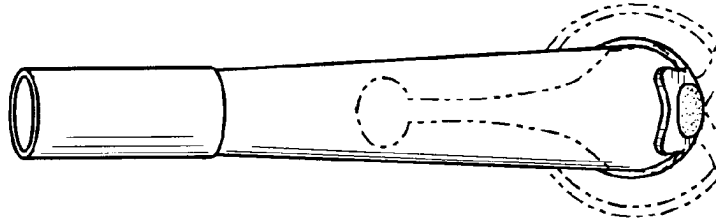

FIG. 6



FIG. 7